

# AutoSPREADER

## Superior Safety & Versatility

### UNIVERSAL:

- One Size Fits All Flange Sizes

### SAFE:

- No Loose Wedges or Parts
- Jaws Open Parallel
- No Drift - It Stays Put
- Can Be Remotely Operated
- Safety Blocks Included

### POWERFUL:

- 10,000 Lbs of Force per Spreader

### WIDE GAP:

- Opens 3" Wide Gap in a Single Pass
- Ample Space for Working in Gap

### SIMPLE OPERATION:

- Easy - One Man Operation
- Lightweight - Just 12 Lbs
- Only 3/32" Needed for Jaw Insertion

### VERSATILE:

- Gasket Maintenance
- Turning Blinds
- Separate Manways
- Open Vessels
- Bearing Removal
- Impeller Removal
- Lifting
- Leveling
- Lowering
- Aligning

### Manual Model MS10K

Simply place the manual AutoSPREADER jaws between the flange faces and turn the ratchet handle. A force of 100 ft-lbs on the 18" ratchet handle provides 10,000 lbs of spreading force to create up to a 3" wide gap.



### Hydraulic Model HS10K

With the hydraulic AutoSPREADER, a five ton hydraulic cylinder provides 10,000 lbs of spreading force. A standard hand pump powers one AutoSPREADER, or multiple units, with ease. As with the manual model, the HS10K provides 10,000 lbs of spreading force per unit, and 20,000 lbs when using a pair. Up to a 3" wide gap can be achieved in a single pass.



### Opens a 3" Wide Gap in a Single Pass



### Inserts into Narrow Gaps

As little as a 3/32" gap is needed for inserting jaws



### Versatile Shop Tool

Lift—Level—Align  
Simplify ordinary tasks



**FASTORQ**<sup>®</sup>  
The Speed of Innovation.

# AutoSPREADER Flange Spreader

**Opens Any Size Flange  
with Controlled Force**

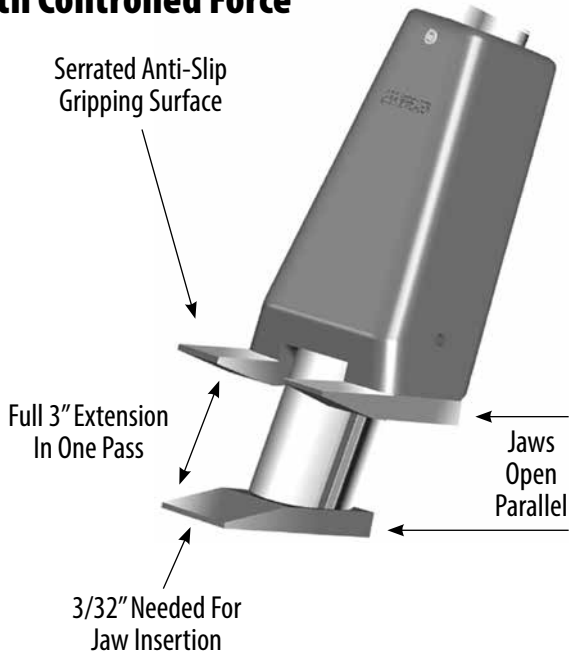

Specification	Imperial		Metric	
	HS10K	MS10K	HS10K	MS10K
Weight	12 lbs	13.5 lbs	5.4 kg	6.1 kg
Length	14"	13.25"	355 mm	336 mm
Width of Jaws	4.5"	4.5"	114 mm	114 mm
Width of Body	4.5"	4.5"	114 mm	114 mm
Jaws Closed	0.09"	0.09"	2.3 mm	2.3 mm
Jaws Open	3"	3"	76.2 mm	76.2 mm
Jaw Penetration	1.5"	1.5"	38.1 mm	38.1 mm
Rated Force	10,000 lbs	10,000 lbs	44.5 kn	44.5 kn

## FASTORQ® POWER UNITS – For Best Speed & Performance

Model	Requirement	Maximum Pressure	Oil Delivery	Value	Reservoir Capacity	Dimensions & Weight	Included Accessories
100 H2 Manual Single Speed	Hand Powered	10,000 PSI	.16 (cu in/stroke)	Controlled Load Holding & Lowering	55 Cl	28" L 4.75" W 6" H 22 lbs	Pair of 12 ft Hoses, Tee Block & Load Lowering Valve
150H2 or 150F2 Manual Two Speed	Hand OR Foot Powered	10,000 PSI	.65 @ 1,400 PSI .16 @ 10,000 PSI (cu in/stroke)	Controlled Load Holding & Lowering	152	28" L 4.75" W 6" H 32 lbs	Pair of 12 ft Hoses, Tee Block & Load Lowering Valve



Model 100H2 Hand Pump



AutoSPREADERS and Safety Blocks are packed in a durable metal toolbox with custom insert

