

FS-XL Series Square Drive Ratchet Wrench

A time tested and proven tool design, square drive ratchets offer a cost efficient option to handle a wide range of bolting make-up and break-out needs. The FS-XL Series ratchet employs a “patented design”, which increases accuracy and reduces the number of moving parts. TL T-6 XL Series body encloses the drive train assembly, allowing no pinch points and lighter weight. Our standard FS-XL Series tool capacities range from 100 to 60,000 Ft. Lbs. of torque, using a 10,000 PSI hydraulic pump.

- Square Drive - For use with all standard size square drive impact sockets. Easily shifts from makeup to break-out without disassembly.
- TL T-6 - XL Series bodies made of durable, highstrength, lightweight aircraft alloy.
- Unibody - Eliminates “Pinch Points”. Reduces side loading. Totally enclosed drive train assembly, allowing nothing in or out of the tool.
- 360 Degree Swivel Fittings - Patented fittings allow hose movement without hose binding, stainless steel with fewer moving parts - a great improvement over competitors’ delicate design. See single plane swivel fittings shown above on wrench.
- Slotted Piston Rod - Maintains 90o relationship between piston rod and nut. Increases accuracy. Reduces number of moving parts.
- Anti-Reverse Pawl - Holds rotational wind-up to maintain required torque.
- Pawl Release - Anti-reverse pawl release mechanism allows manual release of tool if “binding occurs.
- Reaction Member - 360 degree rotation and made of TL T-6. Increased reaction area. Ratchet can be used without reaction member.
- Coated - All exposed parts to resist corrosion.
- Light/Ergonomic - Reduces operator fatigue.
- Calibrated - Every tool is tested and calibrated to +/- .03 accuracy, traceable to N.I.S.T.
- Warranty - FS-XL Series wrenches come with a 1 Year Total Assurance Guarantee.



Extra light, dependable, and fits where others cannot.

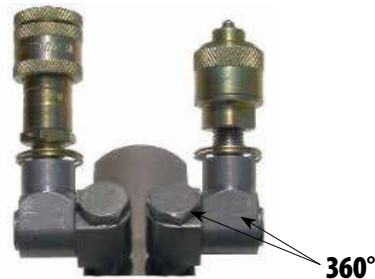

Dual Plane Swivel Fittings Available Upon Request



FS-XL Series Square Drive Ratchet Wrench

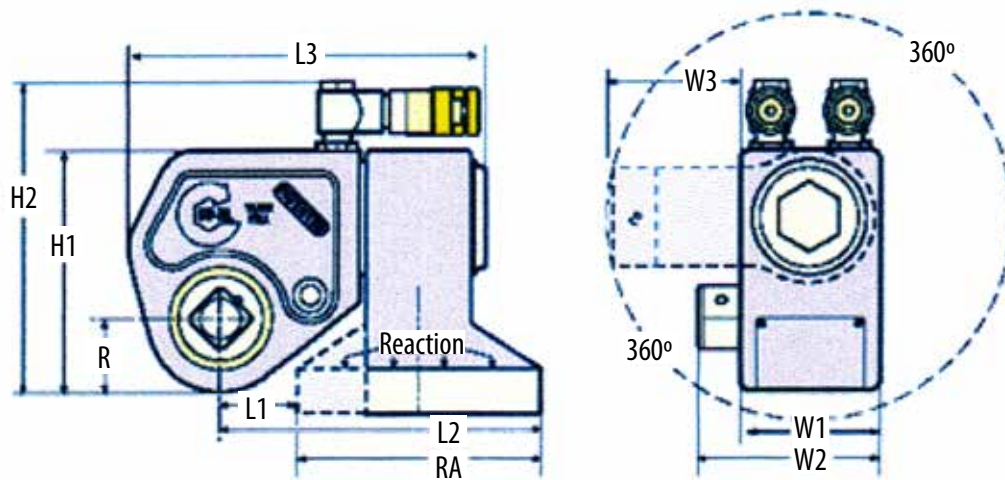

FS-XL Series	Square Drive	Max ft. lbs. @ 10,000 PSI	Weight*	Reaction Area- RA	Length L1	Length L2	Length L3	Radius R	Height H1	Height H2	Width W1	Width W2	Width W3
FS-1XL	3/4"	1,400	5.25 lbs	3.685"	1.567"	5.252"	5.978"	1.200"	4.100"	5.725"	1.980"	2.730"	2.200"
FS-3XL	1"	3,300	11.25 lbs	5.335"	1.865"	7.200"	7.970"	1.260"	4.870"	6.520"	2.775"	3.600"	3.172"
FS-6XL	1-1/2"	6,000	17.20 lbs	5.460"	2.150"	7.610"	8.410"	1.953"	6.250"	7.850"	3.000"	4.475"	3.501"
FS-11XL	1-1/2"	11,300	29.90 lbs	6.500"	2.245"	8.745"	9.500"	2.062"	7.375"	9.125"	3.900"	5.350"	4.982"
FS-20XL	2-1/2"	20,100	62.00 lbs	7.525"	3.460"	10.375"	11.600"	3.000"	9.184"	10.784"	4.950"	7.450"	5.557"
FS-30XL	2-1/2"	30,200	75.00 lbs	7.525"	3.460"	10.875"	11.725"	3.125"	9.777"	11.377"	5.875"	8.375"	5.555"

* Weight includes tool, reaction member and square drive.

FS-XL Series	Square Drive	Max ft. lbs. @ 10,000 PSI	Weight*	Reaction Area- RA	Length L1	Length L2	Length L3	Radius R	Height H1	Height H2	Width W1	Width W2	Width W3
FS-45	2-1/2"	46,200	145.00 lbs	7.425"	7.337"	12.537"	13.312"	3.000"	11.000"	12.600"	5.750"	8.250"	5.500"
FS-60	2-1/2"	60,000	295.00 lbs	8.781"	5.887"	14.668"	16.000"	3.750"	14.000"	15.600"	7.250"	9.750"	5.750"

* Steel Casting

