

HydraPULL Model MK1085 Hydraulic Bundle Extractor

**Low Cost Alternative to traditional chain hoist, crane and other rigging methods
for removing tube bundles from shell and tube exchangers.**

Regular maintenance is essential to the success of exchanger operations. Periodically, all exchangers will require that bundles be pulled and cleaned. The MK-1085 HydraPULL offers an economical solution over traditional methods of removing tube bundles from exchangers.

The basic HydraPULL does not require plant air or source of electric power. It is conveniently mobile and can be easily assembled and disassembled at the job site.

Designed for maximum flexibility in an operating process plant, the HydraPULL can be operated by as few as two maintenance personnel after setup. The unit is completely self-contained, and requires no out-side rigging or gantries.

Essentially, the HydraPULL functions as a jack to remove the bundle from an exchanger with a pushing action. Push rod extensions (see figure 2) are added to the hydraulic cylinder at the completion of each stroke series, and the cycle is then repeated as necessary until complete removal of the tube bundle is achieved. The same operation is used with all bundle sizes that are covered by the particular design of the HydraPULL.

To replace a tube bundle, the operation is reversed and a cable is used in lieu of extension rods. The cable is inserted through a tube in the bundle and attached to a pull plate (see figure 3). The opposite cable end is attached to a pull rod and the bundle is pulled back into the exchanger shell with another series of strokes using the hydraulic cylinder and pump. This action is repeated until the tube bundle is completely in place.

Fig. 1

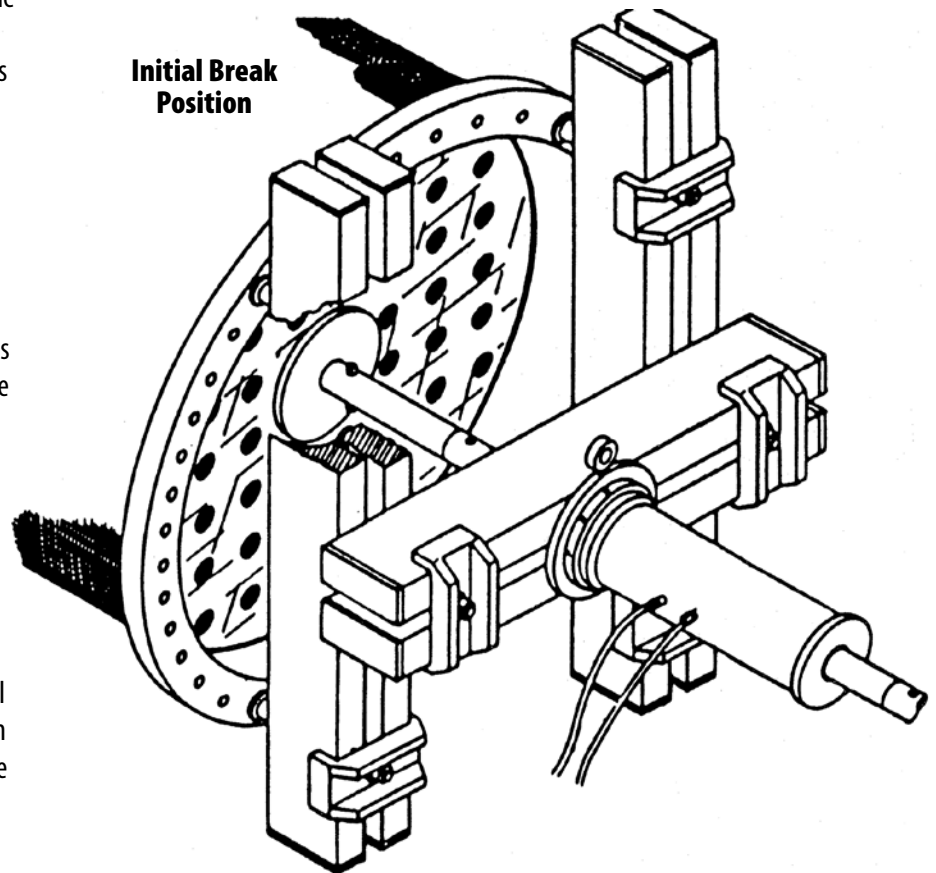

HydraPULL Model MK-1085

**For the Safe Removal & Installation
of Through-Tube Bundles**



HydraPULL Model MK1085 Hydraulic Bundle Extractor

The basic Hydrapull is built around a 50-ton capacity cylinder for use on exchangers up to twenty (20) feet. Each unit is manufactured to the customer's order according to client designated specifications within the plant to meet their particular exchanger, or range of exchanger requirements.

Each unit is furnished with adjustable mounting apparatus consisting of a bridge on which the cylinder is mounted, and to which the

bridge extensions are attached. Push rod extensions are supplied in convenient lengths for use on tube bundles from 3 to 20 feet.

Other standard items furnished include standoff legs, hydraulic hoses with quick connectors, a hand operated two-stage hydraulic pump and all necessary bolting for assembly of the unit to an exchanger.

Pump Options:

Model 205A Air/Hydraulic

Model 215E Electric/Hydraulic

(both units include hoses & fittings)

Capacity of the Basic MK1085 Unit:		
Hydraulic Cylinder	50 tons	45 tonnes
Minimum Exchanger Diameter	20 inches	508 millimeters
Maximum Exchanger Diameter	60 inches	1.52 meters
Maximum Exchanger Length	20 feet	6.10 meters
Maximum Stroke of Cylinder	6 inches	152 millimeters
Maximum Push/Pull Length	20 feet	6.10 meters

