

AutoSPREADER Flange Spreader

**Opens Any Size Flange
with Controlled Force**

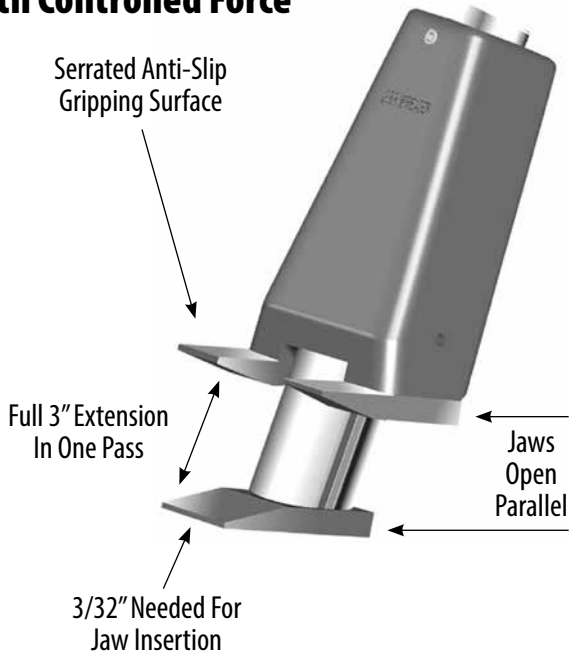

Specification	Imperial		Metric	
	HS10K	MS10K	HS10K	MS10K
Weight	12 lbs	13.5 lbs	5.4 kg	6.1 kg
Length	14"	13.25"	355 mm	336 mm
Width of Jaws	4.5"	4.5"	114 mm	114 mm
Width of Body	4.5"	4.5"	114 mm	114 mm
Jaws Closed	0.09"	0.09"	2.3 mm	2.3 mm
Jaws Open	3"	3"	76.2 mm	76.2 mm
Jaw Penetration	1.5"	1.5"	38.1 mm	38.1 mm
Rated Force	10,000 lbs	10,000 lbs	44.5 kn	44.5 kn

FASTORQ® POWER UNITS – For Best Speed & Performance

Model	Requirement	Maximum Pressure	Oil Delivery	Value	Reservoir Capacity	Dimensions & Weight	Included Accessories
100 H2 Manual Single Speed	Hand Powered	10,000 PSI	.16 (cu in/stroke)	Controlled Load Holding & Lowering	55 Cl	28" L 4.75" W 6" H 22 lbs	Pair of 12 ft Hoses, Tee Block & Load Lowering Valve
150H2 or 150F2 Manual Two Speed	Hand OR Foot Powered	10,000 PSI	.65 @ 1,400 PSI .16 @ 10,000 PSI (cu in/stroke)	Controlled Load Holding & Lowering	152	28" L 4.75" W 6" H 32 lbs	Pair of 12 ft Hoses, Tee Block & Load Lowering Valve



Model 100H2 Hand Pump



AutoSPREADERS and Safety Blocks are packed in a durable metal toolbox with custom insert

